

## EGP150P12AC

### Magnetic

Outdoor Black Powder Coated Steel Enclosure

Double Circuit: **12/24VAC**

Total Wattage: **150W max**

Input Voltage: **120V 60Hz**



Conforms to UL STD. 2108  
Certified to CSA  
STD. C22.2 No 250.0  
model EM150  
[Link to certification](#)

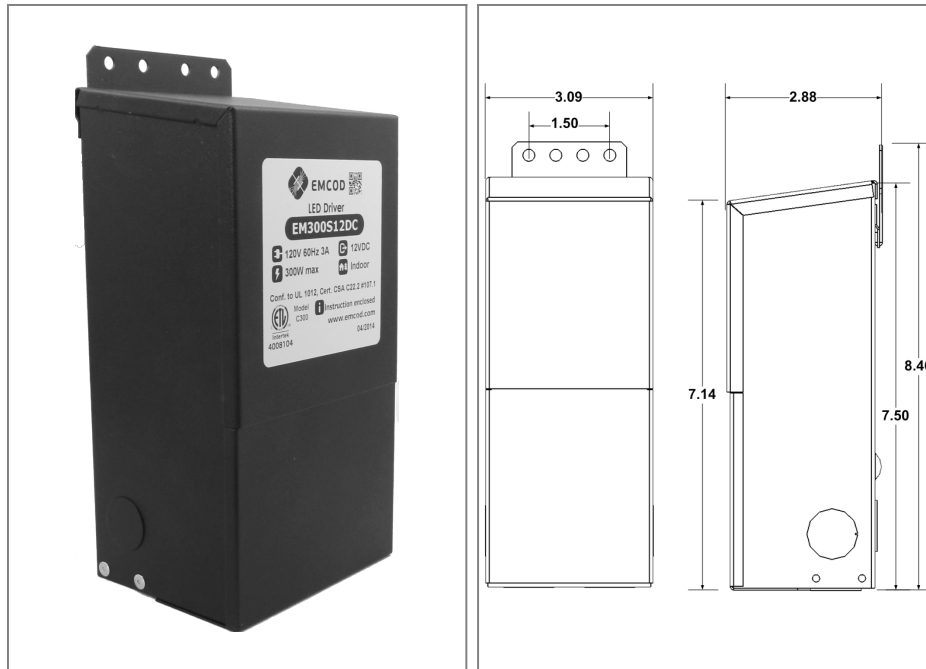

### Transformer

Temperature class B(130°C)

Two section bobbin completely separated primary and secondary windings

Input leads are 18AWG 600V

Output leads are 12AWG 300V

Leads max. operational temperature is 105°C

Thermal manually reset primary breaker 2A per circuit

### Housing

The actual transformer 150W is encapsulated in the enclosure

The enclosure is Black Powder Coated Steel, NEMA 3R rated

Wiring compartment has 6 knockouts sizes for 3/8 inch screw cable connectors

Enclosure Temperature does not exceed 75°C at 45°C ambient and fully loaded

Dimensions (inch): H = 7.5, W = 3.1, D = 2.94

Weight (LBs): 6

### Electrical Parameters

Input Voltage: **120V 60Hz**

Max. input current at full load: **1.5A**

Output voltage without load: **13.9/ 25.8VAC**

Output voltage fully loaded: **11.8/ 23.8VAC**

Max. Total Wattage: **150W** Max. per circuit: **75W**

Max. Output Current: **12.5/ 6.2A** per circuit.

Efficiency: **87%**

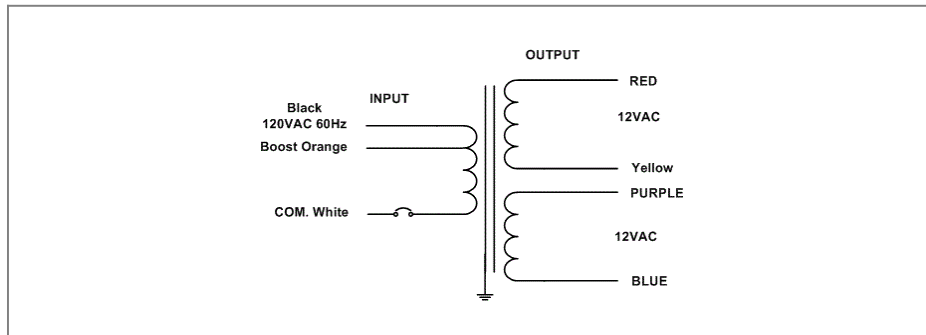

Mailing Address: 646 Flinn Ave. Unit B, Moorpark, CA 93021 Tech support: Arik Nirenberg phone: 818-904-3309

Fax: 818 904 3327 info@emcod.com techsupport@emcod.com