

MLE500-12DC-UD T24

Electronic UNIV 5 in 1 dimming

Outdoor Black Powder Coated Steel Enclosure

Multi Circuit: **12VDC 20kHz PWM, T24 JA-8**

Total Wattage: **500W max**

Input Voltage: **100-277V 50/60Hz**



Conforms to UL STD. 8750
 Certified to CSA
 STD. C22.2 No 250.0
 model MLE500-12DCUD

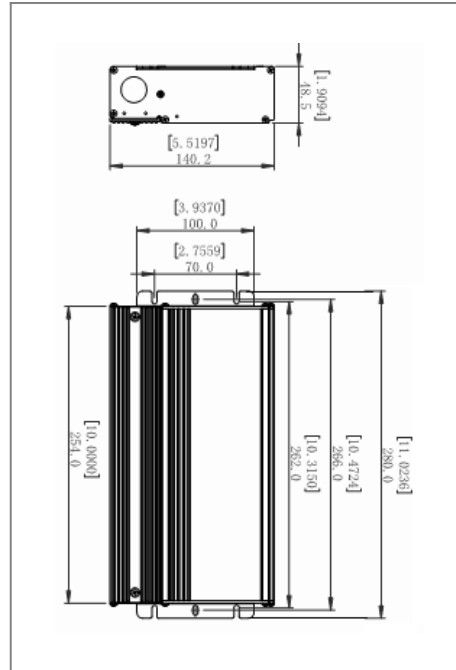

Transformer

Dimmable with triac forward and reverse phase, 0/1-10V, resistor, PWM
 Input leads are 18AWG 600V
 Output leads are 14AWG 300V
 Leads max. operational temperature is 105°C per circuit

Housing

The actual transformer 500W is encapsulated in the enclosure
 The enclosure is Black Powder Coated Steel, NEMA 3R rated
 Wiring compartment has 12 knockouts sizes for 3/8 inch screw cable connectors
 Working ambient temperature range: -40°C (-40°F) to 60°C (140°F)
 Enclosure Temperature does not exceed 70°C at 45°C ambient and fully loaded
 Dimensions (inch): H = 5.52, W = 11.02, D = 1.97
 Weight (LBs): 5.2

Electrical Parameters

Input Voltage:	100-277V 50/60Hz	
Max. input current at full load:	4.8A	
Output voltage without load:	12.1VDC	
Output voltage fully loaded:	12VDC	
Max. Total Wattage:	500W	Max. per circuit: 167W
Max. Output Current:	14A per circuit.	
Efficiency:	90%	
Load regulation:	1%	
Ripple:	5%	

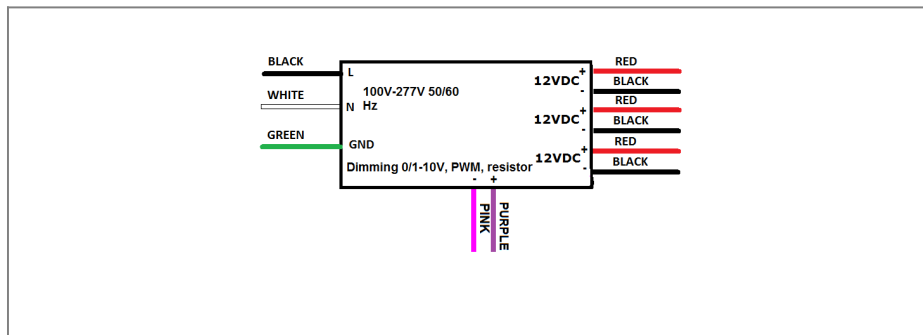

Mailing Address: 646 Flinn Ave. Unit B, Moorpark, CA 93021 Tech support: Arik Nirenberg phone: 818-904-3309
 Fax: 818 904 3327 info@emcod.com techsupport@emcod.com