

Triac/0-10V/1-10V/Potentiometer/10V PWM 5 in 1 Dimmable led driver

KVG-DWJ 300W

Whole Family

KVG-XXXXX-DWJ 12V/ 24VDC
30W 60W 80W 96W 100W
120W 150W 200W 300W



TYPE HL



■Features

- Output constant voltage
- UL, cUL listed, Type HL rated. FCC
- Universal AC input: 110-277VAC
- Power Factor: up to 0.99
- High efficiency : up to 92%
- Load: 10-100%
- Protection:short circuit/over loading/ Over temperature
- PWM output, does not change the color index
- Full protection metal case, for dry, damp, wet location
- Flicker-free
- Dimming function:
Phase dimming: work with forward phase /leading edge ,MLV and
Reverse phase /trailing edge ,ELV,TRIAC dimmers
0-10V dimming: 0-10V/1-10V/Potentiometer/10V PWM 4 in 1
- Dimming range: 0-100%
- Suitable for LED lighting and moving sign applications

Model		KVG-12300-DWJ		KVG-24300-DWJ	
Certificates		UL, cUL listed, Type HL rated, FCC			
Output	DC Voltage	12V		24V	
	Rated Current	25A		12.5A	
	Rated Power	300W		300W	
	Voltage Tolerance	±0.5V			
	Voltage Regulation	±0.5%			
	Load Regulation	±2%		±1%	
Input	Voltage Range	110-277VAC			
	Frequency Range	47-63Hz			
	Power Factor (Typ.) @ full load	0.99@120VAC 0.97@277VAC		0.99@120VAC 0.95@277VAC	
	THD (Typ.) @ full load	<20%			
	Efficiency (Typ.) @ full load	86% @120Vac 88%@277Vac		88% @120Vac 92%@277Vac	
	AC Current (Max.)	3.4A@100Vac			
	Inrush Current (Typ.)	20A, 50%, 1.9ms @120Vac		35A, 50%, 1.9ms @277Vac	
	Leakage current	<0.50mA			
Protection	Short Circuit	shut down o/p voltage, re-power on to recover after fault condition is removed			
	Over Loading	≤120% Hiccup mode,recovers automatically after fault condition is removed			
	Over temperature	100°C±10°C shut down o/p voltage, automatically recover after cooling.			
Environment	Working TEMP.	-40~+60°C (see below derating curve)			
	Working Humidity	20~90%RH, non-condensing			
	Storage TEMP. Humidity	-40~+80°C, 10~95%RH			
	TEMP .coefficient	±0.03%/°C (0~50°C)			
	Vibration	10~500Hz, 5G 10min./1 cycle,period for 60min. each along X,Y,Z axes			
Safety& EMC	Safety standards	UL8750+UL1310			
	Withstand voltage	I/P-O/P:1.88KVAC			
	Isolation resistance	I/P-O/P:100MΩ/500VDC/25°C/70%RH			

Triac/0-10V/1-10V/Potentiometer/10V PWM 5 in 1 Dimmable led driver

KVG-DWJ 300W

	EMC EMISSION	FCC Part 15 B
others	Net. Weight	2.0Kg
	Size	278*110*45mm (L*W*H)
	packing	10PCS/CTN
Notes	1. All parameters if NOT specially mentioned are measured at 120VAC input , rated load and 25°C of ambient temperature. 2. To extend the driver's using life ,please reduce the loading at lower input voltage.	

■ Derating Curve

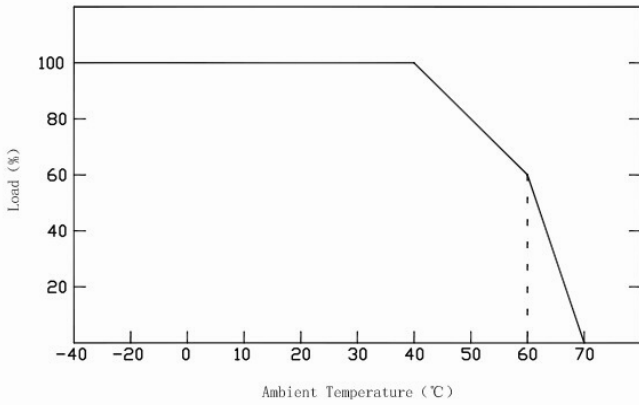

※To extend their life, please refer to the Derating Curve and derate according to the temperature.

■ Mechanical Specification

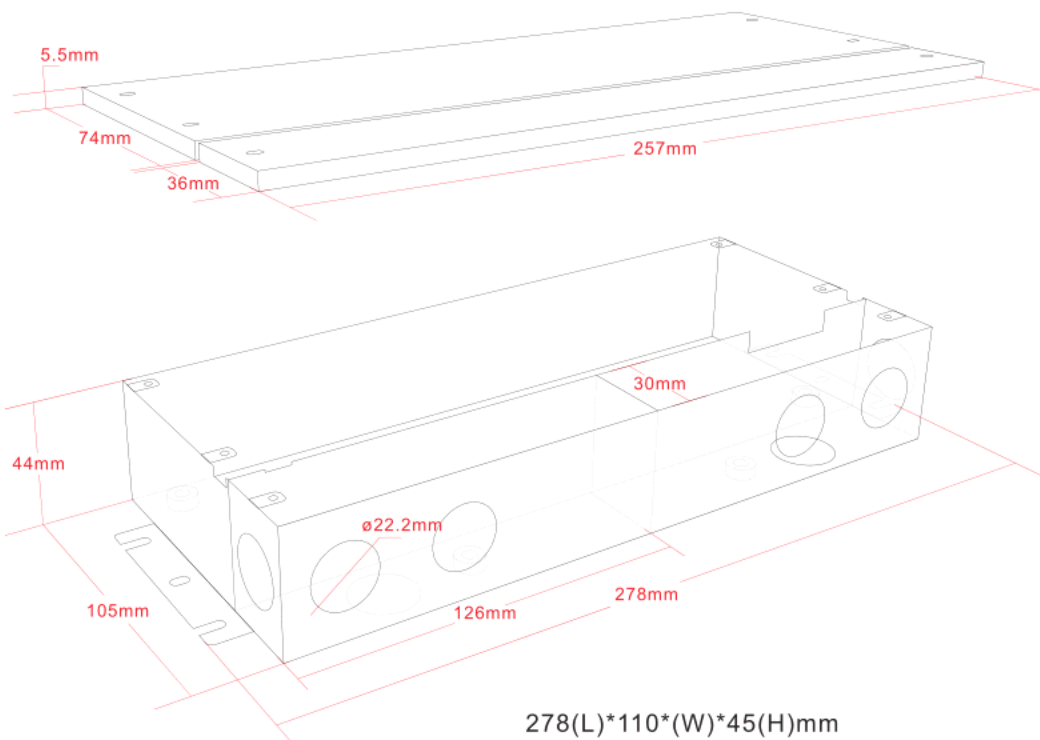

Unite: mm
Tolerance: 0.5-2mm

278(L)*110*(W)*45(H)mm

Triac/0-10V/1-10V/Potentiometer/10V PWM 5 in 1 Dimmable led driver

KVG-DWJ 300W

- ※ Input wire Black and White to be connected to AC L and N ,Green wire go ground,
- ※ Output wire Red to LED Positive side (+) , Black to LED Negative side (-).
- ※ Dimming cable DIM (+) Purple to 0/1-10V dimmer signal(+) ,DIM (-) Grey to 0/1-10V dimmer signal (-)
- ※ Please make sure your connect these correctly otherwise your product will not function correctly and could be damaged.
- ※ Note: Any other requests we can customized.

■ Connecting Diagram

※Using TRIAC/Phase cut dimming

- 1.The Pulse-Width Modulation (PWM) of output voltage can be adjusted through input terminal of the AC phase line(L) by connection a phase /Triac dimmer of lighting system.
- 2.Work with forward phase /leading edge ,MLV and reverse phase /trailing edge ,ELV,TRIAC dimmers.
- 3.Please try to use dimmers with power at least 1.5 times as the output power of the driver.

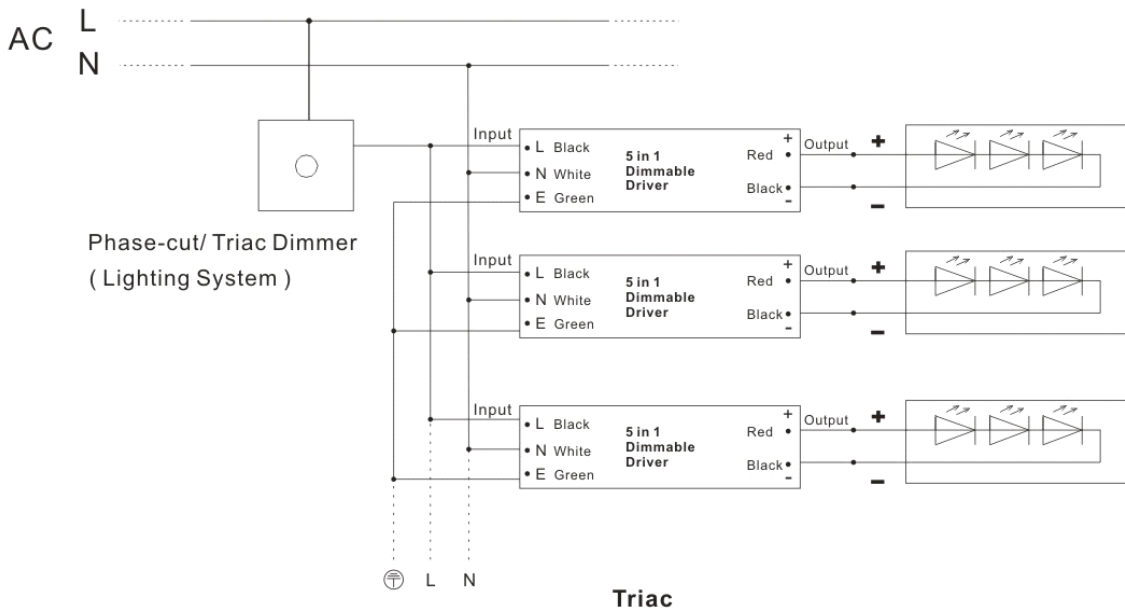

※Using 0-10V/1-10V dimming

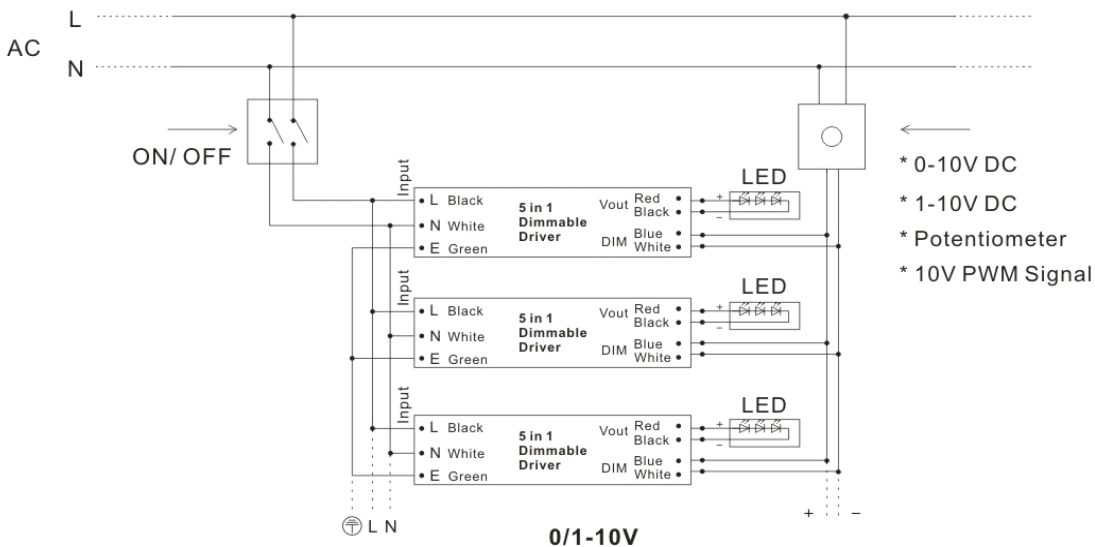

Triac/0-10V/1-10V/Potentiometer/10V PWM 5 in 1 Dimmable led driver

KVG-DWJ 300W

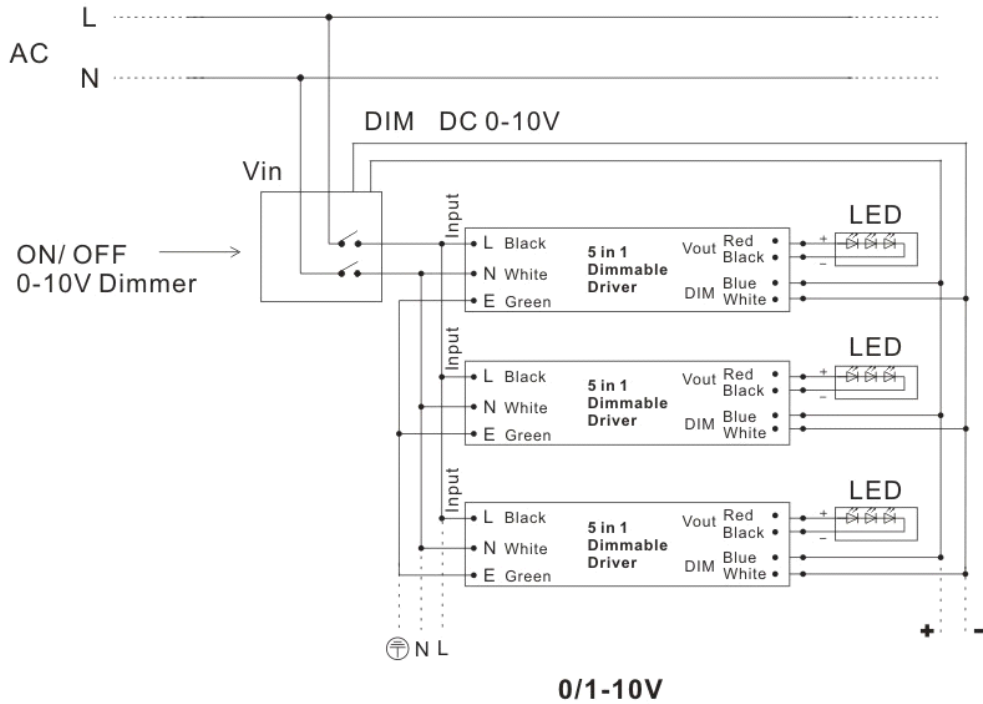

Instruction:

- 1) This driver should be installed by qualified and professional person;
- 2) Please make sure the driver is installed with adequate ventilation around it to allow for heat dissipation.
- 3) Ensure that wiring is correct before test in order to avoid light and power supply damage;
- 4) If driver Cannot work normally, don't maintain privately; Have any question, please contact Zhuhai Shengchang.