

EM3-150S12DC

Class 2 Magnetic

Outdoor Black Powder Coated Steel Enclosure

Multi Circuit: **12VDC**

Total Wattage: **150W max**

Input Voltage: **120V 60Hz**



Conforms to UL STD. 2108
Certified to CSA
STD. C22.2 No 250.0
model EM3

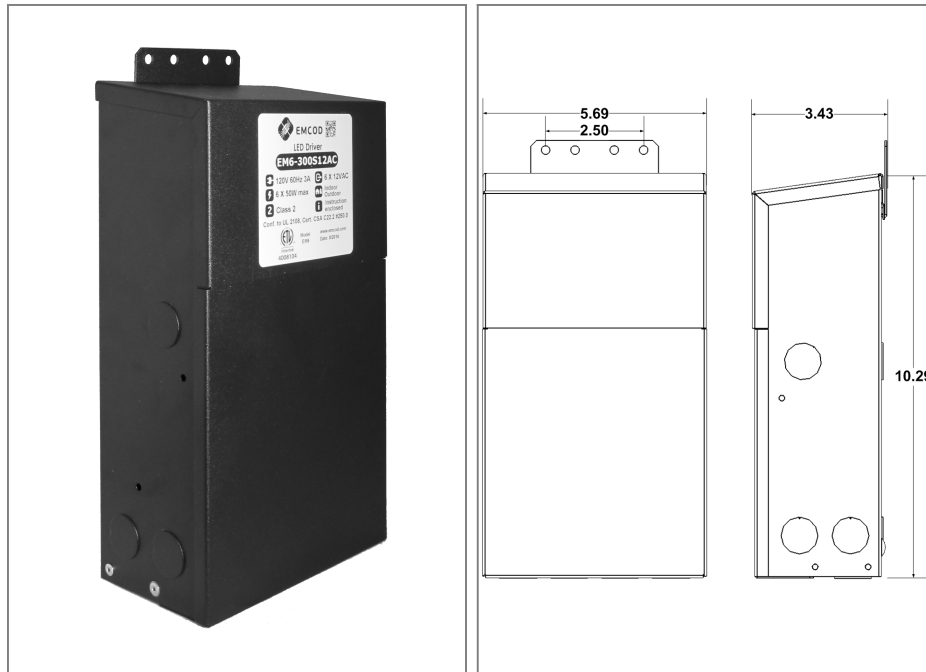

Transformer

Temperature class B(130°C)

Two section bobbin completely separated primary and secondary windings

Input leads are 18AWG 600V

Output leads: Terminal Block

Leads max. operational temperature is 105°C

Thermal manually reset primary breaker 2A

Thermal manually reset secondary breaker 4A per circuit

Housing

The actual transformer 150W is encapsulated in the enclosure

The enclosure is Black Powder Coated Steel, NEMA 3R rated

Wiring compartment has 13 knockouts sizes for 3/8 inch screw cable connectors

Enclosure Temperature does not exceed 75°C at 45°C ambient and fully loaded

Dimensions (inch): H = 10.29, W = 5.69, D = 3.43

Weight (LBs): 0.85

Electrical Parameters

Input Voltage: **120V 60Hz**

Max. input current at full load: **1.5A**

Output voltage without load: **12.8VDC**

Output voltage fully loaded: **11.8VDC**

Max. Total Wattage: **150W**

Max. per circuit: **50W**

Max. Output Current: **4A per circuit.**

Efficiency: **90%**

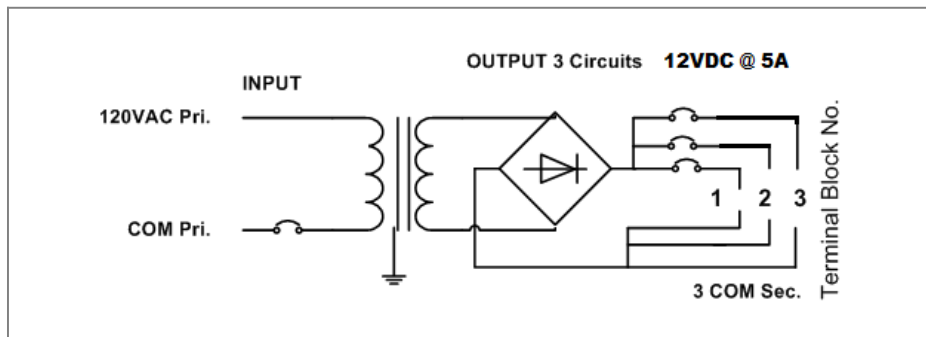

Mailing Address: 646 Flinn Ave. Unit B, Moorpark , CA 93021 Tech support: Arik Nirenberg phone: 818-904-3309

Fax: 818 904 3327 info@emcod.com techsupport@emcod.com