

## EPC200W

### Magnetic Non Dimmable

Outdoor Black Powder Coated Steel Enclosure

Multi Tap: **12VAC and 15VAC**

Total Wattage: **200W max**

Input Voltage: **120V 60Hz**



Conforms to UL STD. 1838  
Certified to CSA  
STD. C22.2 № 250.0, 250.7

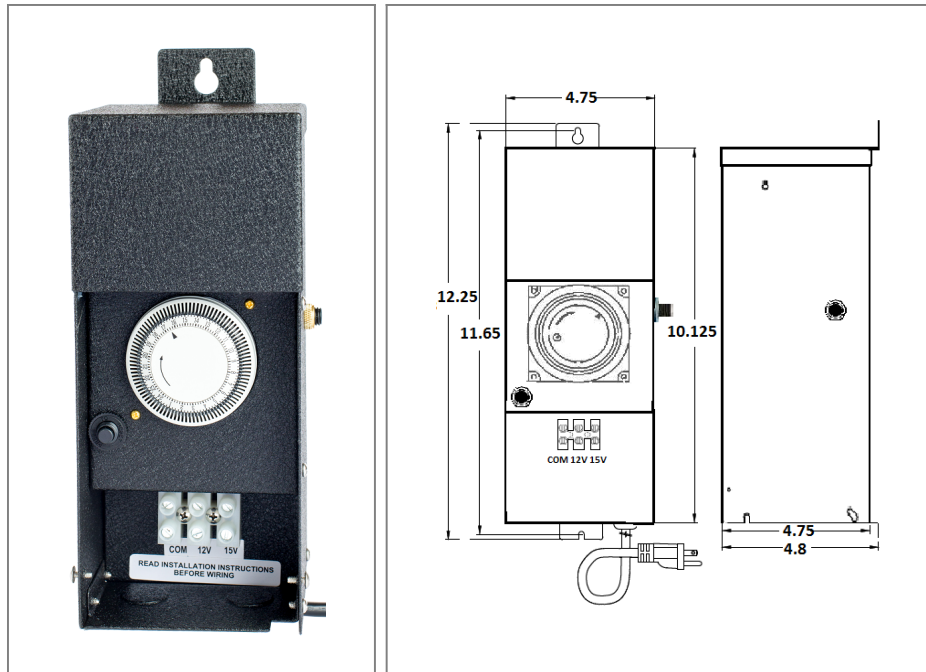

### Transformer

Non Dimmable

Temperature class B(130°C)

Timer and photocell build in options

### Housing

The actual transformer 200W is encapsulated in the enclosure

The enclosure is Black Powder Coated Steel, NEMA 3R rated

Wiring compartment has 2 knockouts sizes for 3/8 inch screw cable connectors

Enclosure Temperature does not exceed 65°C at 45°C ambient and fully loaded

Dimensions (inch): H = 12.25, W = 4.75, D = 4.8

Weight (LBs): 1

### Electrical Parameters

Input Voltage: **120V 60Hz**

Max. input current at full load: **2A**

Output voltage without load: **12/ 15VAC**

Output voltage fully loaded: **11.5/ 14.5VAC**

Max. Total Wattage: **200W**

Max. Output Current: **16.7/ 13.3A**

Efficiency: **90%**

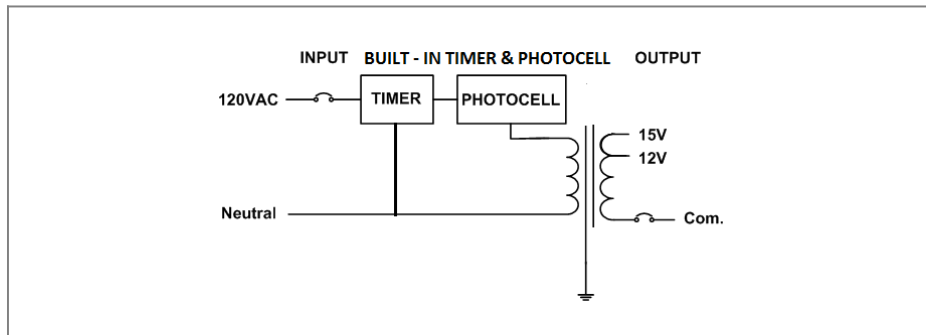

Mailing Address: 646 Flinn Ave. Unit B, Moorpark , CA 93021 Tech support: Arik Nirenberg phone: 818-904-3309

Fax: 818 904 3327 [info@emcod.com](mailto:info@emcod.com) [techsupport@emcod.com](mailto:techsupport@emcod.com)