

# EM600S24DC

## Magnetic Phase cut Dimmable

Outdoor Black Powder Coated Steel Enclosure

Single Circuit: **24VDC**

Total Wattage: **600W max**

Input Voltage: **120V 60Hz**



Conforms to UL STD. 2108  
Certified to CSA  
STD. C22.2 No 250.0  
model EM600  
[Link to certification](#)

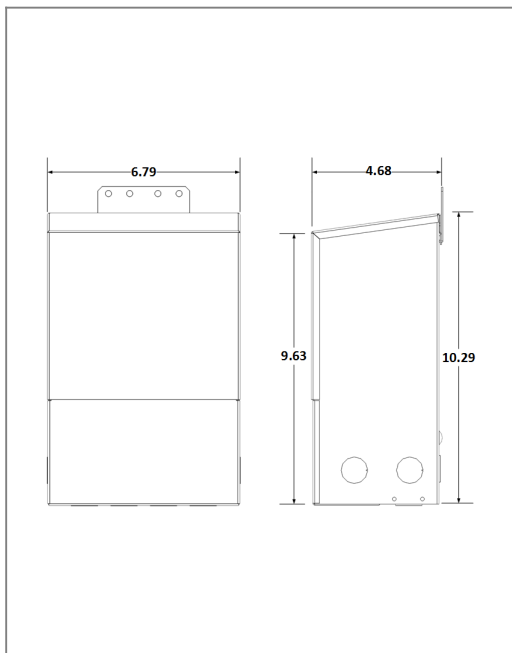

### Transformer

Dimmable with compatible MLV, ELV, CL dimmers, please refer to list on emcod.com

Temperature class B(130°C)

Two section bobbin completely separated primary and secondary windings

Input leads are 18AWG 600V

Output leads are 12AWG 300V

Leads max. operational temperature is 105°C

Thermal manually reset primary breaker 10A

Thermal manually reset secondary breaker 25A

### Housing

The actual transformer 600W is encapsulated in the enclosure

The enclosure is Black Powder Coated Steel, NEMA 3R rated

Wiring compartment has 12 knockouts sizes for 3/8 inch screw cable connectors

Enclosure Temperature does not exceed 75°C at 45°C ambient and fully loaded

Dimensions (inch): H = 10.29, W = 6.79, D = 4.68

Weight (LBs): 18

### Electrical Parameters

Input Voltage: **120V 60Hz**

Max. input current at full load: **6A**

Output voltage without load: **25VDC**

Output voltage fully loaded: **23.5VDC**

Max. Total Wattage: **600W**

Max. Output Current: **25A**

Efficiency: **93%**

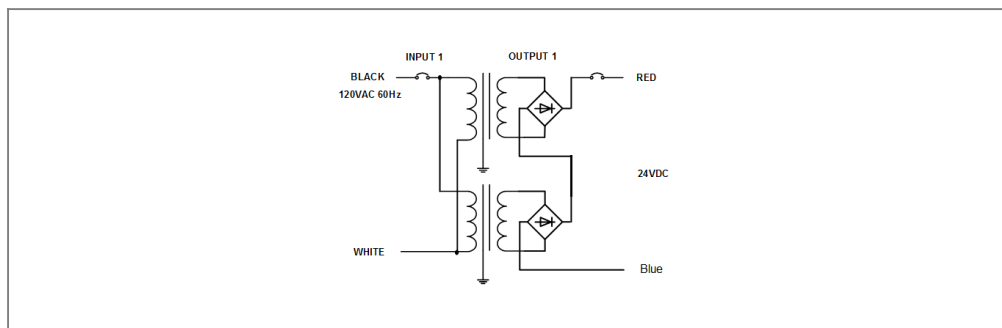

Mailing Address: 6925 Eton Ave. Canoga Park, CA 91303 Tech support: Arik Nirenberg phone: 818-904-3309 cellphone: 818-269-4091  
Fax: 818 904 3327 info@emcod.com techsupport@emcod.com