

EGP250P12AC

Magnetic

Outdoor Black Powder Coated Steel Enclosure

Double Circuit: **12/24VAC**

Total Wattage: **250W max**

Input Voltage: **120V 60Hz**



Conforms to UL STD. 2108
Certified to CSA
STD. C22.2 No 250.0
model EM300
[Link to certification](#)

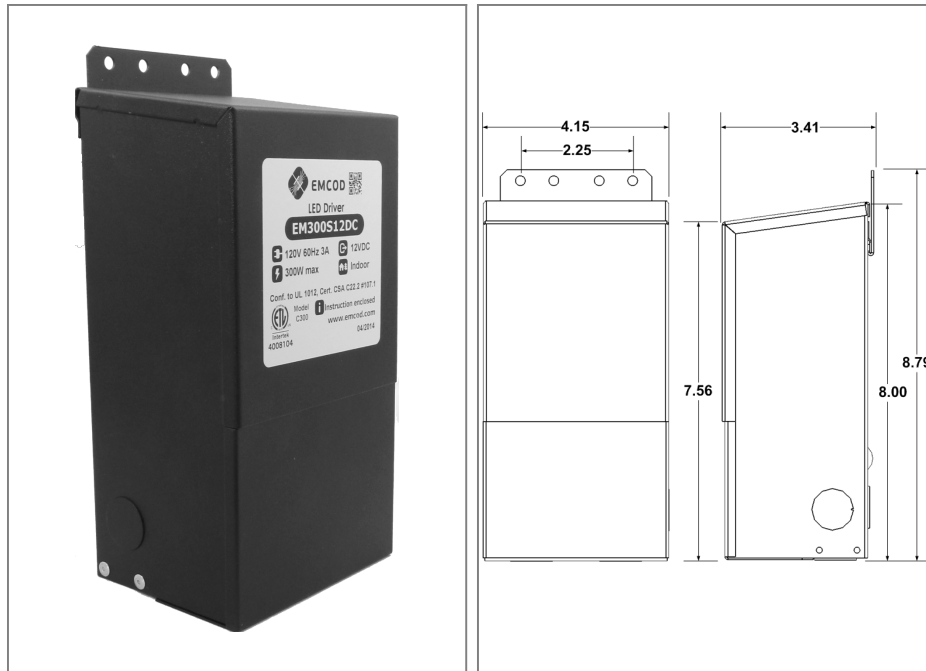

Transformer

Temperature class B(130°C)

Two section bobbin completely separated primary and secondary windings

Input leads are 18AWG 600V

Output leads are 12AWG 300V

Leads max. operational temperature is 105°C

Thermal manually reset primary breaker 5A per circuit

Housing

The actual transformer 250W is encapsulated in the enclosure

The enclosure is Black Powder Coated Steel, NEMA 3R rated

Wiring compartment has 6 knockouts sizes for 3/8 inch screw cable connectors

Enclosure Temperature does not exceed 75°C at 45°C ambient and fully loaded

Dimensions (inch): H = 8, W = 4.1, D = 3.1

Weight (LBs): 9

Electrical Parameters

Input Voltage: **120V 60Hz**

Output voltage without load: **12.7/ 24.8VAC**

Output voltage fully loaded: **11.8/ 23.8VAC**

Max. Total Wattage: **250W** Max. per circuit: **125W**

Max. Output Current: **20.8/ 10.4A** per circuit.

Efficiency: **93%**

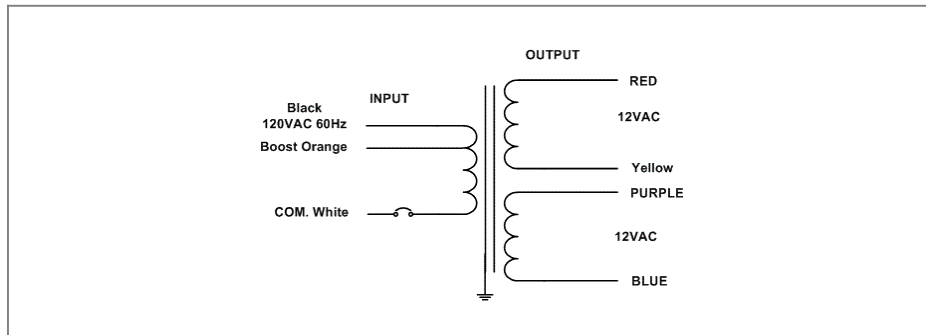

Mailing Address: 646 Flinn Ave. Unit B, Moorpark , CA 93021 Tech support: Arik Nirenberg phone: 818-904-3309

Fax: 818 904 3327 info@emcod.com techsupport@emcod.com