

EGS300P12AC

Magnetic Dimmable

Outdoor Stainless Steel Enclosure

Double Circuit: **12/24VAC**

Total Wattage: **300W max**

Input Voltage: **120V 60Hz**



Conforms to UL STD. 2108
Certified to CSA
STD. C22.2 № 250.0
model EM300
[Link to certification](#)

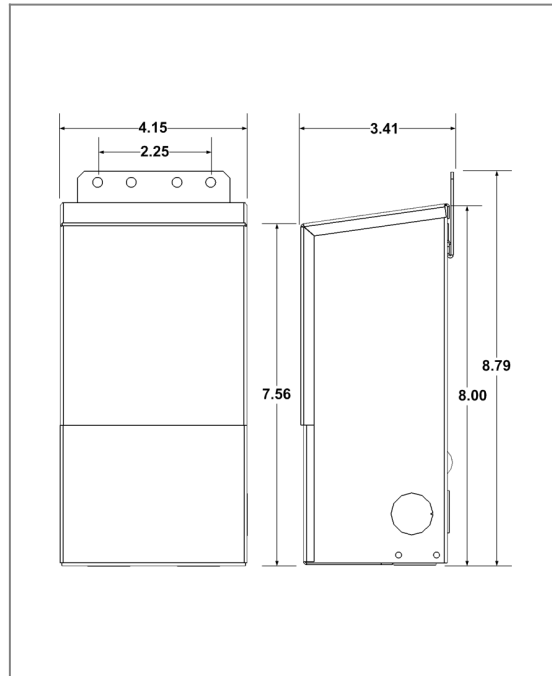

Transformer

Dimmable with any LV magnetic dimmer as long as you cover dimmer's min load.

Temperature class B(130°C)

Two section bobbin completely separated primary and secondary windings

Input leads are 18AWG 600V

Output leads are 12AWG 300V

Leads max. operational temperature is 105°C

Thermal manually reset primary breaker 5A

25A per circuit

Housing

The actual transformer 300W is encapsulated in the enclosure

The enclosure is Stainless Steel, NEMA 3R rated

Wiring compartment has 6 knockouts sizes for 3/8 inch screw cable connectors

Enclosure Temperature does not exceed 75°C at 45°C ambient and fully loaded

Dimensions (inch): H = 8, W = 4.1, D = 3.1

Weight (LBs): 9

Electrical Parameters

Input Voltage:	120V 60Hz
Max. input current at full load:	2.8A
Output voltage without load:	12.4/ 24.8VAC
Output voltage fully loaded:	11.8/ 23.8VAC
Max. Total Wattage:	300W Max. per circuit: 150W
Max. Output Current:	25/ 12.5A per circuit.
Efficiency:	93%

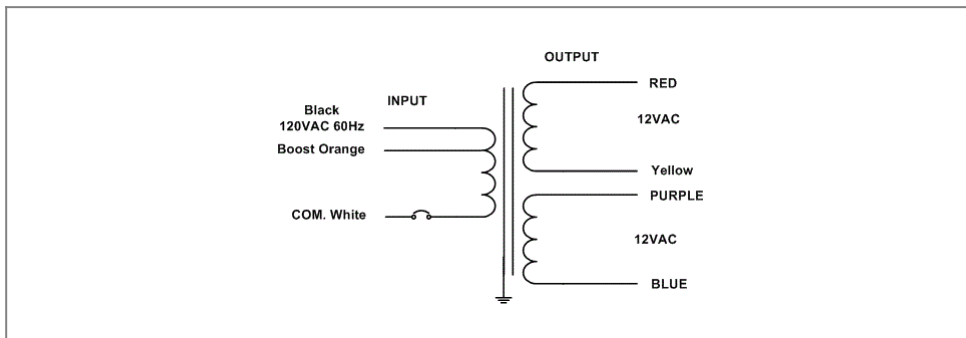

Mailing Address: 6925 Eton Ave. Canoga Park, CA 91303 Tech support: Arik Nirenberg phone: 818-904-3309 cellphone: 818-269-4091
Fax: 818 904 3327 info@emcod.com techsupport@emcod.com