

EM600S2X12DC-2P

Magnetic Dimmable

Outdoor Black Powder Coated Steel Enclosure

Double Circuit: **2 X 12VDC**

Total Wattage: **600W max**

Input Voltage: **2 X 120V 60Hz**



Conforms to UL STD. 2108
Certified to CSA
STD. C22.2 No 250.0
model EM600
[Link to certification](#)

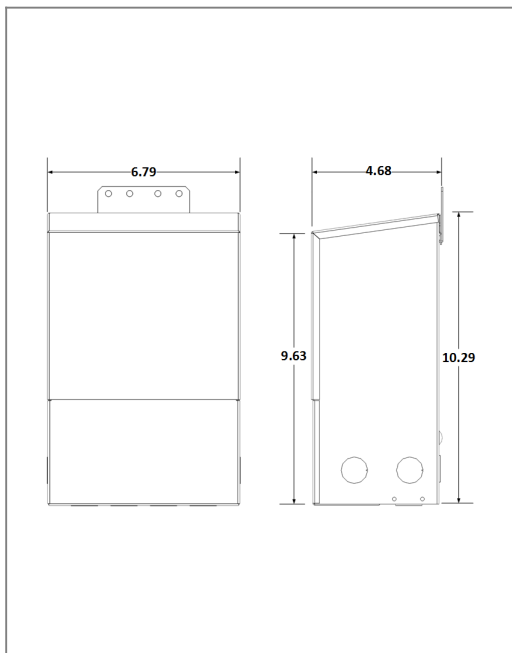

Transformer

Dimmable with any MLV, CL dimmer, as long as, dimmer's min. load is covered.

Temperature class B(130°C)

Two section bobbin completely separated primary and secondary windings

Input leads are 18AWG 600V

Output leads are 12AWG 300V

Leads max. operational temperature is 105°C

Thermal manually reset primary breaker 5A

Thermal manually reset secondary breaker 25A per circuit

Housing

The actual transformer 600W is encapsulated in the enclosure

The enclosure is Black Powder Coated Steel, NEMA 3R rated

Wiring compartment has 12 knockouts sizes for 3/8 inch screw cable connectors

Enclosure Temperature does not exceed 75°C at 45°C ambient and fully loaded

Dimensions (inch): H = 10.29, W = 6.79, D = 4.68

Weight (LBs): 18

Electrical Parameters

Input Voltage:	2 X 120V 60Hz	
Max. input current at full load:	6A	
Output voltage without load:	12.5VDC	
Output voltage fully loaded:	11.5VDC	
Max. Total Wattage:	600W	Max. per circuit: 300W
Max. Output Current:	25A per circuit.	
Efficiency:	93%	

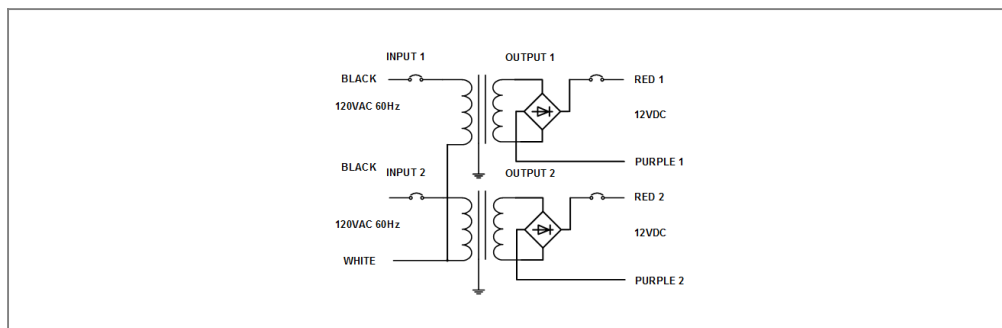

Mailing Address: 6925 Eton Ave. Canoga Park, CA 91303 Tech support: Arik Nirenberg phone: 818-904-3309 cellphone: 818-269-4091
Fax: 818 904 3327 info@emcod.com techsupport@emcod.com